

# APC Symmetra RM

## Installation Manual

English

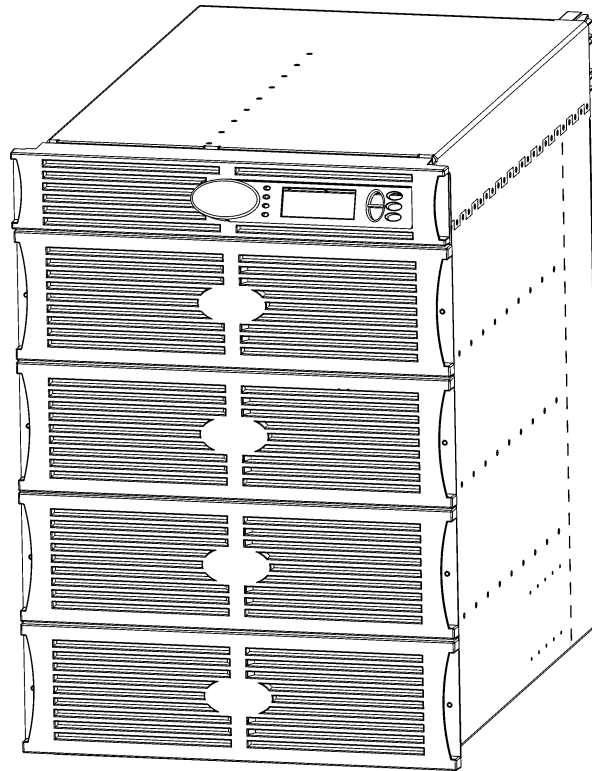

**APC**  
www.apc.com



# TABLE OF CONTENTS

## APC Contact Numbers and Support

Visit the APC Web site for contact numbers and support at <http://www.apc.com/support>.

## Battery Replacements Kits and Battery Recycling

See your dealer or visit the APC web site at <http://www.apc.com> for information on battery replacement kits and battery recycling. If returning used batteries to APC for recycling, ship used batteries in the battery replacement packing material.

<b>Chapter 1: Safety and General Information.....</b>	<b>1</b>
Save These Instructions .....	1
Conventions Used in this Manual .....	1
General Equipment Safety .....	1
Handling Safety .....	1
Deenergizing Safety.....	2
Electrical Safety.....	2
Battery Safety .....	2
Radio Frequency Interference.....	3
North America and 208 V Countries .....	3
Europe and 230 V Countries .....	3
Japan and 200 V Countries .....	3
Regulatory Agency Approvals .....	3
Declaration of Conformity (Europe and 230 V Countries) .....	4
Life Support Policy.....	5
Limited Warranty.....	5
Copyright and Trademark Information.....	5
<b>Chapter 2: Basics.....</b>	<b>7</b>
About Your UPS.....	7
Product Overview .....	9
Front View Component Identification .....	9
Rear View Component Identification .....	10
System Block Diagram .....	11
<b>Chapter 3: Site Preparation .....</b>	<b>13</b>
Reminder Checklist .....	13
Purchase of System.....	13
Site Preparation.....	13
Electrical Preparation.....	13

**TABLE OF CONTENTS**



- Chapter 4: Installation..... 14**
  - Shipping & Receiving..... 14
  - Short-Term Battery Module Storage Requirements ..... 14
  - Installation Requirements ..... 15
  - Electrical Requirements..... 16
  - Unpacking..... 17
    - Inspection..... 17
    - Contents ..... 17
  - Installing the UPS ..... 17
    - Moving the UPS to the Installation Site..... 18
    - Installing in a Four Post Rack ..... 20
    - Wiring the UPS ..... 23
    - Completing the Installation ..... 26
    - Connecting Load Equipment to the UPS ..... 28
    - Final Installation Checklist ..... 29
  - Post Installation Procedures..... 30
    - Replacing Battery Modules..... 30
    - Replacing Power Modules ..... 30
    - Replacing Intelligence Modules..... 31
- Chapter 5: Specifications..... 33**
  - UPS Specifications ..... 33

## Save These Instructions



This safety section contains important instructions that should be followed during installation and maintenance of the APC equipment.

## Conventions Used in this Manual







The following symbols are used throughout this manual. Carefully read all information boxes and abide by the instructions.

	The WARNING sign denotes a serious hazard. It calls attention to a procedure, practice, condition, or the like, which, if not correctly performed or adhered to, could result in injury to personnel.
	The CAUTION sign denotes a hazard. It calls attention to an operating procedure, practice, or the like, which, if not correctly performed or adhered to, could result in damage to or destruction of all or part of the product.
	The NOTE sign denotes important information. It calls attention to a procedure, practice, condition, or the like, which is essential to highlight.

## General Equipment Safety

	<ul style="list-style-type: none"> <li>• Connection to the branch circuit (mains) must be performed by a licensed electrician.</li> <li>• Installation and removal of the power, battery, intelligence modules, and interface accessories must be performed by service personnel.</li> </ul>
	Operation of the equipment can be performed by any individual with no previous technical experience.

## Handling Safety

	<p>Be careful. Do not lift heavy loads without assistance.</p> <p>⇒ &lt;18 kg (&lt;40 lb)  ⇒ 32 – 55 kg (70 – 120 lb) </p> <p>⇒ 18 – 32 kg (40 – 70 lb)  ⇒ &gt;55 kg (&gt;120 lb) </p>
	This equipment is intended for installation in a temperature-controlled indoor area free of conductive contaminants. Refer to <i>Specifications</i> at the APC web site for the actual temperature range.

## CHAPTER 1: SAFETY AND GENERAL INFORMATION

### Deenergizing Safety

---

	<p>The UPS contains internal batteries and may present a shock hazard even when disconnected from the branch circuit (mains). Before installing or servicing the equipment, ensure that the system enable switch and input circuit breaker are set to stand by (off), that internal battery modules are removed, that external extended run batteries are disconnected, and the branch circuit (mains) is disconnected.</p>
---	---



### Electrical Safety

---

	<ul style="list-style-type: none"><li>• The protective earth conductor for the UPS carries the leakage current from the load devices (computer equipment). Therefore, the size of the conductor must be at least as large as the wire required by IEC 950. An insulated grounding conductor that is identical in size, insulation material, and thickness to the grounded and ungrounded branch-circuit supply conductors, except that it is green with or without a yellow stripe is to be installed as part of the branch circuit that supplies the UPS.</li><li>• The grounding conductor described above is to be grounded to earth at the service equipment, or if supplied by a separately derived system, at the supply transformer or motor-generator set.</li><li>• The attachment-plug receptacles near or in the vicinity of the unit or subsystem are all to be of a grounding type, and the grounding conductors serving these receptacles are to be connected to earth ground at the service equipment.</li></ul>
---	---

### Battery Safety

---

	<ul style="list-style-type: none"><li>• Each battery module is a 120 V, 7.2Ah battery pack. There is a risk of energy hazard. Before installing or replacing battery modules, remove jewelry such as wristwatches and rings. High short circuit current through conductive materials could cause severe burns.</li><li>• Do not dispose of batteries in a fire. The batteries may explode.</li><li>• Do not open or mutilate batteries. Released electrolyte is harmful to the skin and eyes, and may be toxic.</li></ul>
	<ul style="list-style-type: none"><li>• Do not install the battery modules in the frame until you are ready to power up the UPS. Failure to do so can result in a deep discharge of the batteries, which may cause permanent damage.</li></ul>
	<ul style="list-style-type: none"><li>• Batteries are recyclable. Used batteries can be sent to APC for recycling or delivered to a recycling facility.</li><li>• Store the battery module(s) at a cool ambient temperature of &lt; 25 °C.</li><li>• Only use APC batteries when installing or replacing battery modules.</li></ul>

## Radio Frequency Interference

### North America and 208 V Countries

	<ul style="list-style-type: none"> <li>This equipment has been tested and found to comply with the limits for a Class A digital device, pursuant to part 15 of the Federal Communications Commission (FCC) rules and the Class A limits for radio noise emissions from digital apparatus set out in the Radio Interference Regulations of the Canadian Department of Communications (CDC). These limits are designed to provide reasonable protection against harmful interference when the equipment is operated in a commercial environment. This equipment generates, uses, and can radiate radio frequency energy and, if not installed and used in accordance with the instruction manual, may cause harmful interference to radio communications. Operation of this equipment in a residential area is likely to cause interference, in which case the user, at his own expense, will be required to take whatever measures may be required to correct the interference. Changes or modifications to this unit not expressly approved by the party responsible for compliance could void the user's authority to operate the equipment.</li> <li>Use shielded signal cables with this product to ensure compliance with Class A FCC limits.</li> </ul>
---	--







### Europe and 230 V Countries

	<p>This is a Class A product. In a domestic environment, this product may cause radio interference, in which case, the user may be required to take corrective actions.</p>
---	---

### Japan and 200 V Countries

	<p>This is a Class A product based on the standard of the Voluntary Control Council for Interference by Information Technology Equipment (VCCI). If this equipment is used in a domestic environment, radio disturbance may occur, in which case, the user may be required to take corrective actions.</p>
---	--

## Regulatory Agency Approvals

Countries	Regulatory Agency Symbols				
<b>North America and 208V Countries</b>	 LISTED 42C2 E96563	 LR63938			
<b>Europe and 230V Countries</b>	 N 394				
<b>Japan and 200 V Countries</b>	 LISTED 42C2 E96563				

## CHAPTER 1: SAFETY AND GENERAL INFORMATION

### Declaration of Conformity (Europe and 230 V Countries)

---

# Declaration of Conformity

**Application of Council Directives:** 89/336/EEC, 73/23/EEC, 91/157/EEC

**Standards to which conformity is declared:** EN55022, EN50082-1, EN50091, EN60950

**Manufacturer's Name and Address:** American Power Conversion (A. P. C.) b. v.  
Breaffy Rd Industrial Estate  
Castlebar, Ireland

-or-

American Power Conversion  
40 Catamore Boulevard  
East Providence, Rhode Island, 02914, USA

-or-

American Power Conversion (A. P. C.) b. v.  
Lot 10 Block 16 Phase IV  
Peza, Rosario  
Cavite, Philippines

**Importer's Name and Address:** American Power Conversion (A. P. C.) b. v.  
Ballybritt Business Park  
Galway, Ireland

**Type of Equipment:** Uninterruptible Power Supply

**Model Numbers:** SY4KRMI, SY4K12RMI, SY8K12RMI,  
SY12K12RMI, SYPM4KU, SYBT3, SYMIM3,  
SYRIM3, SYCC, SYXRCC, SYRMR4I

**Serial Numbers:** CD0115 000000 — CD0652 999999  
ED0115 000000 — ED0652 999999  
QD0115 000000 — QD0652 999999

**Years of Manufacture:** 2000, 2001, 2002, 2003, 2004, 2005, 2006

We, the undersigned, hereby declare that the equipment specified above conforms to the above directives.

Billerica, MA  
Place

5/1/00  
Date

  
\_\_\_\_\_  
William Burke  
Regulatory Compliance Engineer

Castlebar, Ireland  
Place

5/1/00  
Date

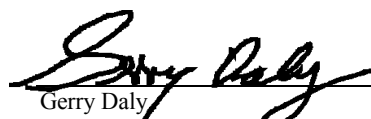
  
\_\_\_\_\_  
Gerry Daly  
Managing Director, Europe



### Life Support Policy

---

As a general policy, American Power Conversion (APC) does not recommend the use of any of its products in life support applications where failure or malfunction of the APC product can be reasonably expected to cause failure of the life support device or to significantly affect its safety or effectiveness. APC does not recommend the use of any of its products in direct patient care. APC will not knowingly sell its products for use in such applications unless it receives in writing assurances satisfactory to APC that (a) the risks of injury or damage have been minimized, (b) the customer assumes all such risks, and (c) the liability of American Power Conversion is adequately protected under the circumstances.

Examples of devices considered to be life support devices are neonatal oxygen analyzers, nerve stimulators (whether used for anesthesia, pain relief, or other purposes), autotransfusion devices, blood pumps, defibrillators, arrhythmia detectors and alarms, pacemakers, hemodialysis systems, peritoneal dialysis systems, neonatal ventilator incubators, ventilators for both adults and infants, anesthesia ventilators, infusion pumps, and any other device designated as “critical” by the U.S.F.D.A.

Hospital grade wiring devices and reduced leakage currents that meet medical safety standards may be ordered as options on many APC UPS systems. APC does not claim that units with these modifications are certified or listed as such by APC or any other organization, therefore these units do not meet the requirements for use in direct patient care.

### Limited Warranty

---

American Power Conversion (APC) warrants its products to be free from defects in materials and workmanship for a period of two years from the date of purchase, except in India where the period is one year for battery module(s). Its obligation under this warranty is limited to repairing or replacing, at its own sole option, any such defective products. To obtain service under warranty you must obtain a Returned Material Authorization (RMA) number from customer support (see *Service* in the SYMMETRA RM OPERATION MANUAL). Products must be returned with transportation charges prepaid and must be accompanied by a brief description of the problem encountered and proof of date and place of purchase. This warranty does not apply to equipment that has been damaged by accident, negligence, or misapplication or has been altered or modified in any way. This warranty applies only to the original purchaser who must have properly registered the product within 10 days of purchase.

EXCEPT AS PROVIDED HEREIN, AMERICAN POWER CONVERSION MAKES NO WARRANTIES, EXPRESSED OR IMPLIED, INCLUDING WARRANTIES OF MERCHANTABILITY AND FITNESS FOR A PARTICULAR PURPOSE. Some states do not permit limitation or exclusion of implied warranties; therefore, the aforesaid limitation(s) or exclusion(s) may not apply to the purchaser.

EXCEPT AS PROVIDED ABOVE, IN NO EVENT WILL APC BE LIABLE FOR DIRECT, INDIRECT, SPECIAL, INCIDENTAL, OR CONSEQUENTIAL DAMAGES ARISING OUT OF THE USE OF THIS PRODUCT, EVEN IF ADVISED OF THE POSSIBILITY OF SUCH DAMAGE. Specifically, APC is not liable for any costs, such as lost profits or revenue, loss of equipment, loss of use of equipment, loss of software, loss of data, costs of substitutes, claims by third parties, or otherwise. This warranty gives you specific legal rights and you may have other rights that vary from state to state.

### Copyright and Trademark Information

---

Entire contents copyright © 2000 by American Power Conversion Corporation. All rights reserved. Reproduction in whole or in part without permission is prohibited.

APC and PowerChute are registered trademarks of American Power Conversion Corporation. All other trademarks are the property of their respective owners.

## **CHAPTER 1: SAFETY AND GENERAL INFORMATION**

## About Your UPS

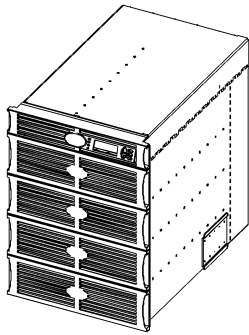

Figure 1: UPS Front View

The Symmetra RM is a high-performance, uninterruptible power system (UPS) in a “power array” configuration, designed to power high availability servers and other sensitive electronic equipment. It provides conditioned, reliable AC power to connected equipment, and provides protection from power blackouts, brownouts, swells, sags, surges, and interference.

The UPS is modular in design and can be configured to deliver a maximum output of 12 kVA N+1 redundant or 16 kVA non-redundant power.

Table 1: System Configurations and Model Numbers

	Complete System– End Item SKU	Available Power kVA	Battery Modules	Power Modules	Nominal Input Voltage	Nominal Output Voltage
<b>North America and 208/240V (Ø- Ø -G)</b>	SYP8K12RMT	8	2	2	208/240	208/240
	SYP12K12RMT	12	3	3		
	SYP8K12RMT-P1	8	2	2	208	120 and 208
	SYP12K12RMT-P1	12	3	3		
	SYP12K12RMT-P2	12	3	3		
<b>Europe and 230V (Ø- N -G)</b>	SYP8K12RMI	8	2	2	220/230/240	220/230/240
	SYP12K12RMI	12	3	3		
<b>Japan and 200 V (Ø- Ø -G)</b>	SYP8K12RMJ	8	2	2	200	200
	SYP12K12RMJ	12	3	3		
	SYP8K12RMJ-P1	8	2	2		100 and 200
	SYP12K12RMJ-P1	12	3	3		
	SYP12K12RMJ-P2	12	3	3		

Table 2: Replacement Modules

	Model Number	Description
<b>Replacement Modules</b>	SYMIM3	Main Intelligence Module
	SYRIM3	Redundant Intelligence Module
	SYPM4KU	4 kVA Power Module
	SYBT3	Battery Module
	SYCC	Communications Card
	AP9606	Web/SNMP Management Card

## CHAPTER 2: BASICS

Table 3: Optional Accessories

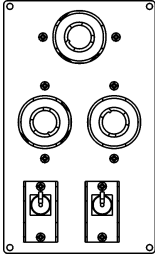
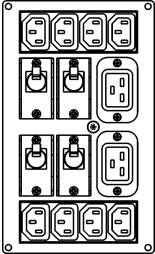
	Model Number	Description	North America and 208/240V (Ø- Ø -G)	Europe and 230V (Ø- N -G)	Japan and 200 V (Ø- Ø -G)
<b>Power Distribution Options</b>	SYTF2	208 Vac to 120 Vac, 5 kVA step-down transformer with (12) 5-20 receptacles	Yes		
	SYTF2J	200 Vac to 100 Vac, 3.5 kVA step-down transformer with (12) 5-20 receptacles			Yes
	SYPD3	(2) L6-20 and (1) L6-30 receptacles	Yes		Yes
	SYPD4	(8) IEC320-C13 and (2) IEC320-C19 receptacles		Yes	
	SYPD5	(8) IEC320-C13 and (2) IEC320-C19 receptacles	Yes		Yes
	SYPD7	(3) L6-20 receptacles	Yes		Yes
  <p style="display: flex; justify-content: space-around;"> <span>SYPD3/SYPD7</span> <span>SYPD4/SYPD5</span> </p>					
<b>Extended Run Options</b>	SYRMXR4	UPS rackmount 4U extended run battery cabinet (holds up to 4 battery modules)	Yes		
	SYRMXR4I	UPS rackmount 4U extended run battery cabinet (holds up to 4 battery modules)		Yes	
	SYRMXR4J	UPS rackmount 4U extended run battery cabinet (holds up to 4 battery modules)			Yes
<b>Smart Slot Management Options</b>	AP9608	Out-of band management card	Yes		
	AP9612TH	Environmental monitoring card			
	AP9610	Relay I/O card			
	AP9615	5-port 10Base-T hub			

Product Overview

Front View Component Identification

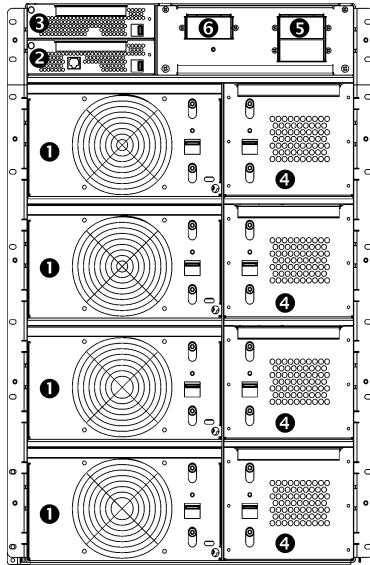

Figure 2: UPS – Front View  
PowerView and Bezels Removed

**Power Module(s) ❶:** Each module can provide up to 4 kVA/2.8 KW power. The UPS frame can support up to four power modules.

**Main Intelligence Module ❷:** The Main Intelligence Module (MIM) performs all monitoring, control, and communication functions.

**Redundant Intelligence Module ❸:** The Redundant Intelligence Module (RIM) provides backup in the event of a MIM failure.

**Battery Module(s) ❹:** Each battery module provides backup energy storage. The UPS frame can support up to four battery modules.

**Input Circuit Breaker ❺:** The input circuit breaker protects the UPS and load equipment from extreme overloads.

**Maintenance Bypass Switch ❻:** Manual control of the bypass function. When the maintenance bypass switch is in the “On” position, power is delivered directly from the branch circuit (mains) to the load equipment.

**Rail Cleats ❼:** Two cleats (one on each side) engage with the rack mounting rails to secure the UPS in the equipment rack.

**Mounting Flanges ❽:** Two mounting flanges are used to secure the UPS to the rack.

**PowerView ❾:** The user interface provides full control, monitoring, and configuration for the UPS.

**Front Bezels ❿:** Blank faceplates cover the power modules, battery modules, and unoccupied bays in the front of the UPS.

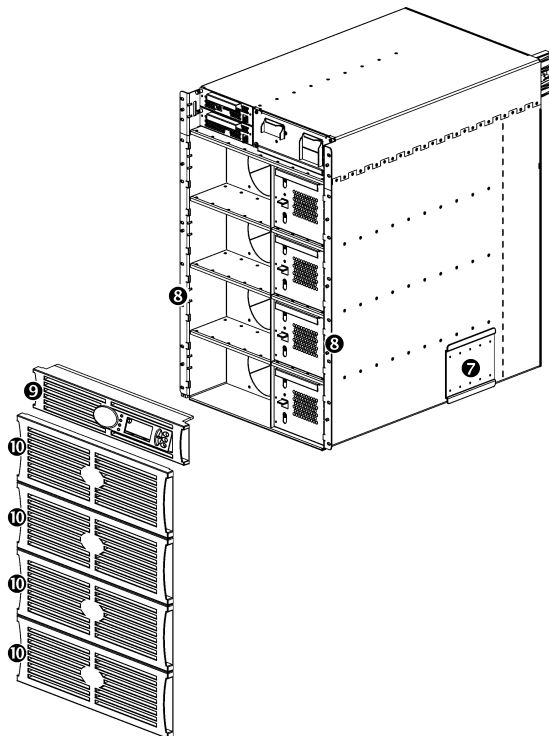

Figure 3: UPS – Front and Side View

## CHAPTER 2: BASICS

### Rear View Component Identification

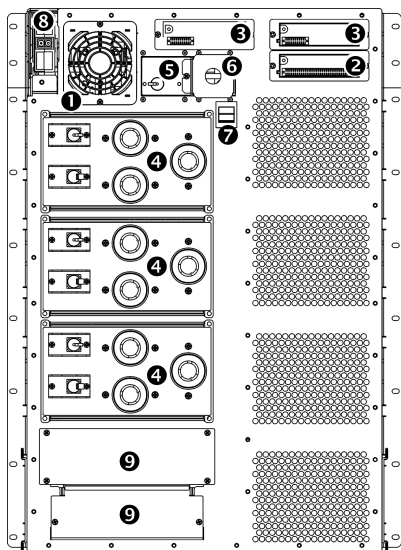

Figure 4: UPS- Rear View  
(SYPD3 installed)

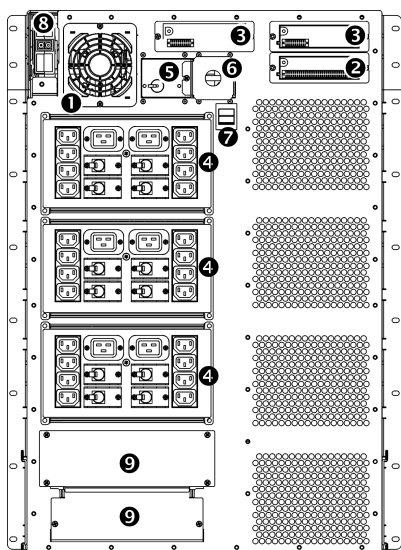

Figure 5: UPS- Rear View  
(SYPD4 installed)

**System Fan ❶:** The system fan provides cooling for frame components.

**Communications Card ❷:** Provides serial interface port for remote management and communications to extended run battery cabinets.

**Accessory Ports ❸:** Two accessory ports are provided for optional SmartSlot™ accessories. A Web/SNMP management card for accessing data via a network is preinstalled.

**Power Distribution Unit (PDU) ❹:** Power distribution panels provide receptacles for connecting load equipment. Panel type is based on configuration.

**System Enable Switch ❺:** When in the “On” position, the UPS powers up internally, but does not power the load. When in the “Off” position, the system powers down internally.

**Remote Emergency Power Off (REPO) Connection ❻:** The REPO provides connection to an emergency power off switch, which shuts off power to the UPS and prevents the unit from operating on-battery. See page 23 for wiring instructions.

**Input Voltage Selection Switch ❼:** Set this switch to correspond to your input power.

**External Battery Cabinet Connector ❸:** Attach an external battery cabinet to the UPS using this connector.

**Input Wiring ❹:** Provides access to wiring terminal blocks for hard wiring the input.

System Block Diagram

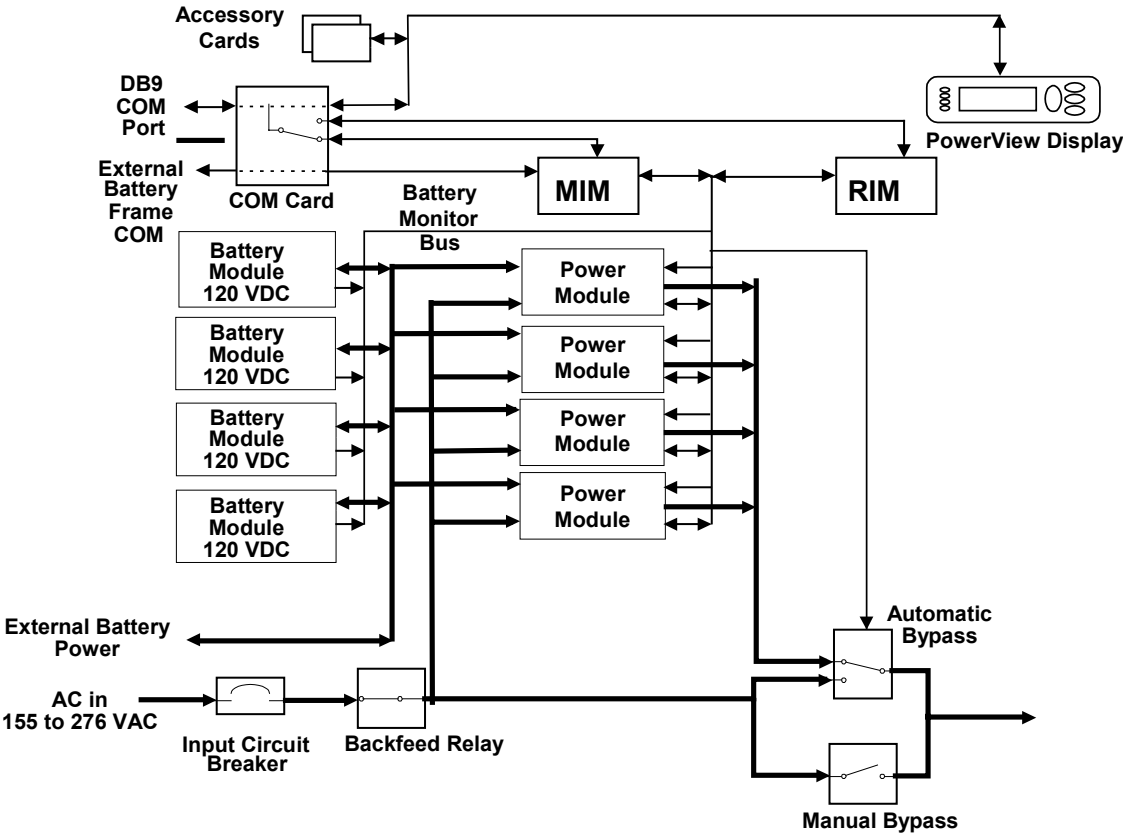

## CHAPTER 2: BASICS



### Reminder Checklist

---

#### ***Purchase of System***

Have you ...

1. determined your load power and runtime requirements?
2. purchased redundant power and battery module if desired?
3. evaluated and selected a service plan?



Refer to [http://www.apc.com/products/symmetra\\_rm](http://www.apc.com/products/symmetra_rm) for answers to these and other questions.

#### ***Site Preparation***

Have you ...

1. determined where to install your UPS and ensured that enough rack space is available?
2. verified that the location will support the weight of the UPS system?
3. ensured that the site meets minimum environmental requirements, including HVAC?



Answers to these and other installation questions can be found in the following sections.

#### ***Electrical Preparation***

Have you ...

1. verified that the required input voltage is available?
2. scheduled an electrician for installation, to hardwire the system?
3. determined all output-wiring configurations to be installed?
4. provided a copy of this document to the electrician?



Answers to these and other wiring questions can be found in the following sections.

## CHAPTER 3: SITE PREPARATION

### Shipping & Receiving



The UPS and modular components are shipped on one or more pallets, depending on the configuration. The frame is installed first and then modular components are installed within the frame.

Weights and Measurements	Length Inches (cm)	Width Inches (cm)	Height Inches (cm)	Weight lbs (kg)
Unpackaged				
Chassis*	27.8 (70.6)	18.9 (48.0)	26.1 (66.3)	185.0 (84.1)
Power module	23.4 (59.4)	10.0 (25.4)	5.2 (13.2)	29.0 (13.2)
Battery module	23.5 (59.7)	6.6 (16.8)	5.2 (13.2)	64.0 (29.1)
Intelligence modules	19.6 (49.8)	6.6 (16.8)	1.6 (4.1)	5.0 (2.3)
Packaged				
Chassis**	36.0 (91.4)	30.0 (76.2)	37.4 (95.0)	264.0 (120.0)
Power module	30.8 (78.2)	12.3 (31.2)	17.0 (43.2)	35.0 (15.9)
Battery module	30.8 (78.2)	12.3 (31.2)	17.0 (43.2)	70.0 (31.8)
Intelligence modules	22.8 (57.9)	12.5 (31.8)	7.3 (18.5)	7.0 (3.2)

\* Overall length including bezel



\*\* Includes rail and accessory bezel kit

### Short-Term Battery Module Storage Requirements

	<ul style="list-style-type: none"> <li>Do not install battery modules until you are ready to power up the UPS. Batteries can be permanently damaged if loaded prematurely.</li> </ul>
	<ul style="list-style-type: none"> <li>Store the battery module(s) at a cool ambient temperature of &lt; 25 °C.</li> <li>Storage of batteries longer than six months without recharging may result in permanent damage.</li> </ul>

**Installation Requirements**

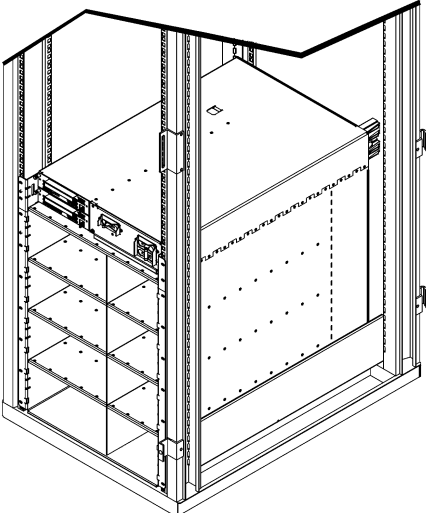

When selecting a location for the UPS, consider the following:

Physical Requirements	
<p>Standard Installation (4-post rack)</p> 	<ul style="list-style-type: none"> <li>• Standard 19 in. (46.5 cm) rack</li> <li>• At least 800mm deep</li> <li>• 15U rack space</li> <li>• Recommended installation is in the bottom of the rack, due to its weight of up to 600 lbs (273 kg), depending on the configuration.</li> <li>• Mounting rails and hardware provided</li> </ul>
<p>Functional Access</p>	<ul style="list-style-type: none"> <li>• Front access for circuit breakers, maintenance bypass, PowerView, and module installation or replacement.</li> <li>• Rear access for system enable switch, power distribution, and management communications.</li> </ul>
<p>Air Flow</p>	<ul style="list-style-type: none"> <li>• Front to rear airflow</li> </ul> <div style="border: 1px solid black; padding: 5px; display: flex; align-items: center;">  <p>Do not block front bezels and vents on rear or sides of the UPS.</p> </div>
Environmental Requirements	
<p>Install the UPS in a temperature controlled, clean, dry, and protected indoor area that is free of conductive contaminants.</p>	
<p>Temperature</p>	<p>0 – 40 degrees Celsius (32 – 104 degrees F)</p>
<p>Relative Humidity</p>	<p>0 – 95% non-condensing</p>
<p>Elevation</p>	<p>0 – 3,000 m (0 – 10,000 ft above mean sea level)</p>
Thermal Dissipation	
<p>UPS 12 kVA N+ 1(Full load)</p>	<p>8811 BTUs typical – Batteries charged 9664 BTUs typical – Batteries charging</p>

# CHAPTER 3: SITE PREPARATION

## Electrical Requirements

The following provides guidance for planning the electrical installation. Check local and national codes. A qualified electrician may be required.

Input Connection				
Method	Maximum Load	Voltage (Vac)	Current Full Load	Connection
Hardwired	16 kVA	200, 208, 220, 230, or 240	100 A	<ul style="list-style-type: none"> <li>External circuit breaker</li> <li>#3 AWG (25 mm<sup>2</sup>)</li> </ul>
Output Connection				
Method	Maximum Load	Voltage (Vac)	Current Full Load	Connection
Hardwired	16 kVA	200, 208, 220, 230, or 240	90 A	<ul style="list-style-type: none"> <li>External circuit breaker</li> <li>#3 AWG (25 mm<sup>2</sup>)</li> </ul>
Cord connected: North America, Japan, and other 200/208/240 Vac countries			Available receptacles: <ul style="list-style-type: none"> <li>(3) L6-30R</li> <li>(6) L6-20R</li> </ul>	
Cord connected: Europe and other 220/230/240 Vac Countries			Available receptacles: <ul style="list-style-type: none"> <li>(8) IEC320-C13</li> <li>(2) IEC320-C19</li> </ul>	
Remote Emergency Power Off (REPO)				
<p>If required, the output power can be disabled in an emergency by closing a switch connected to the REPO.</p> <p>Two connection methods are available:</p> <ul style="list-style-type: none"> <li>Internally powered for use with non-powered switch circuits.</li> <li>Externally powered for use with +24Vdc powered switch circuits.</li> </ul>			<div style="border: 1px solid black; padding: 5px;">  <ul style="list-style-type: none"> <li>Use one of the following cable types to connect the UPS to the REPO switch:               <ul style="list-style-type: none"> <li>CL2: Class 2 cable for general use.</li> <li>CL2P: Plenum cable for use in ducts, plenums, and other spaces used for environmental air.</li> <li>CL2R: Riser cable for use in a vertical run in a shaft of from floor to floor.</li> <li>CLEX: Limited use cable for use in dwellings and for use in raceways.</li> </ul> </li> <li>For installation in Canada: Use only CSA Certified, type ELC (extra-low voltage control cable).</li> <li>Wiring by a qualified electrician is required.</li> </ul> </div>	
<div style="border: 1px solid black; padding: 5px;">  <ul style="list-style-type: none"> <li>The REPO circuit is considered a Class 2 (UL and CSA standards) and SELV (IEC standard) circuit.</li> <li>Both Class 2 and SELV circuits must be isolated from all primary circuitry. Do not connect any circuit to the REPO terminal block unless it can be confirmed that the circuit is SELV or Class 2. If there is a question, use a contact closure switch.</li> </ul> </div>				

### Unpacking

---

The UPS and accompanying components is packaged in a robust shipping carton. Carefully remove the package contents. The UPS and modular components are shipped on one or more pallets, depending on the configuration. The packaging is recyclable; save it for reuse or dispose of it properly.

#### ***Inspection***

Inspect the equipment upon receipt. APC has designed robust packaging for your product. However, accidents and damage may occur during shipment. Notify the carrier and dealer if there is damage or missing equipment.

#### ***Contents***

Check the packaging contents. Two shipping pallets are included: (1) contains the shrink-wrapped boxed UPS on a pallet. The UPS box contains the transportation cart, rail kit (containing the mounting rails and hardware) accessory bezel kit (containing two transportation cart brackets, display bezel with Powerview, four blank bezels, blank panel kit, and literature kit); and (2) contains the individually boxed and shrink-wrapped power and battery modules. The number of each depends on the configuration ordered.

### Installing the UPS



---

This section provides information on the steps required to install and connect the UPS.

The UPS is designed for use in a data center or other office environment. Refer to *Chapter 3: Site Preparation* to select a location.

## CHAPTER 4: INSTALLATION

### *Moving the UPS to the Installation Site*

	<ul style="list-style-type: none"><li>• The UPS is heavy. Two people, one on each side, must support the UPS when it is being transported on the cart to the rack; installed, or removed from the rack.</li><li>• A qualified electrician must install or remove battery modules.</li><li>• Two people are required to lift, move, install, or remove battery and power modules. The battery and power modules are heavy.</li></ul>
	<p>Do not install battery modules until you are ready to power up the UPS. Batteries can be permanently damaged if loaded prematurely.</p>
	<ul style="list-style-type: none"><li>• To comply with FAA regulations, the battery modules are shipped disconnected to the UPS.</li><li>• Mounting rails are included with the UPS. The rails support the unit in the rack.</li></ul>

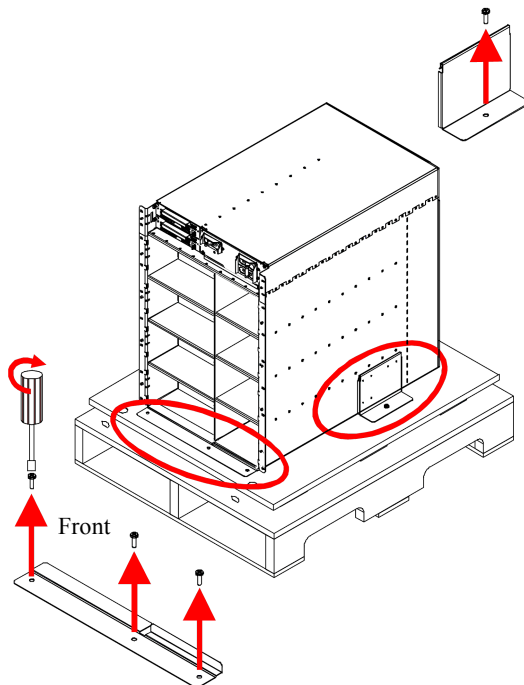

1. Remove the bolts securing the shipping brackets to the pallet.

# CHAPTER 4: INSTALLATION

- 2. Use the metal brackets (contained in the mounting rail kit) to attach the cart to the pallet.

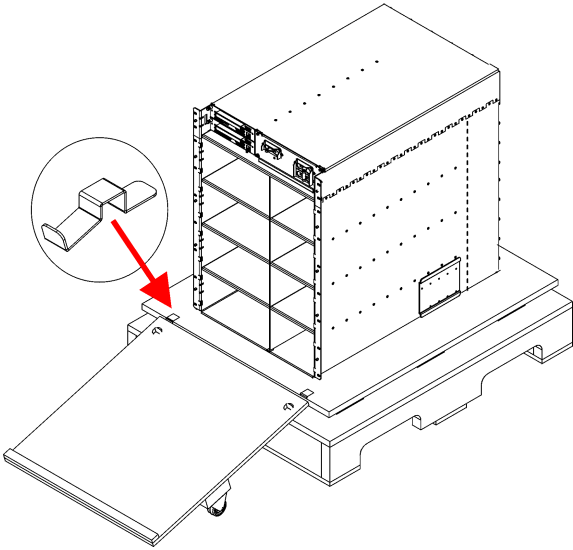

- 3. Transfer the UPS to the cart.

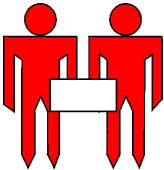

	Two people are required to lift, move, or install the UPS due to its weight.
--	--

- Slide the UPS onto the cart.
- Once the UPS is on the cart, pull the cart away from the pallet.
- Remove the metal brackets from the cart and pallet.

- 4. Move the UPS on its cart to the front of the equipment rack where it will be installed.

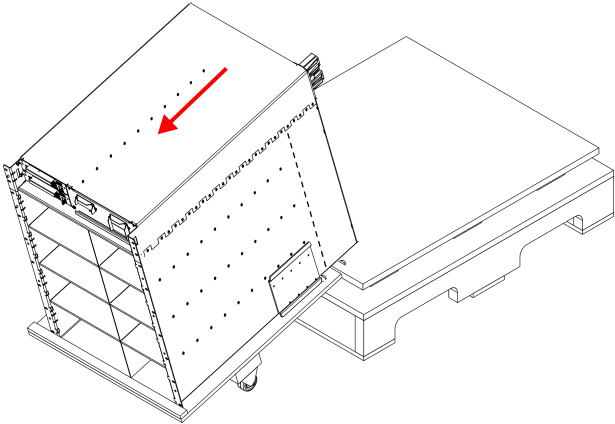

# CHAPTER 4: INSTALLATION

## Installing in a Four Post Rack

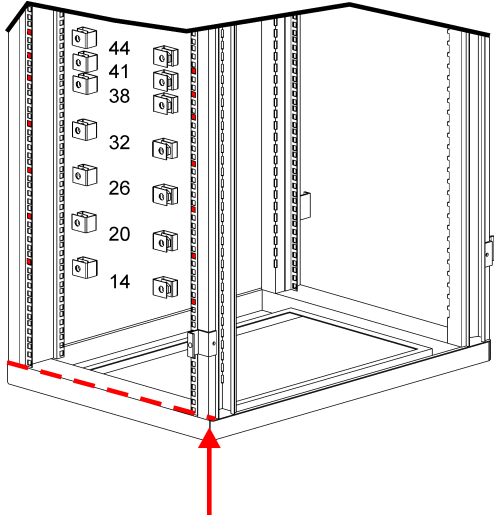

Bottom of UPS

1. Install the clip nuts in the rack.

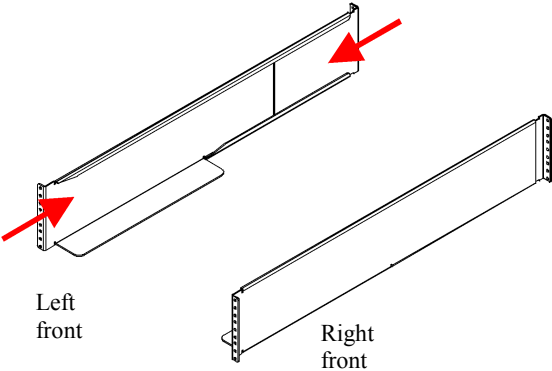

2. Assemble the rails as shown.



# CHAPTER 4: INSTALLATION

3. Install the rails in the rack.

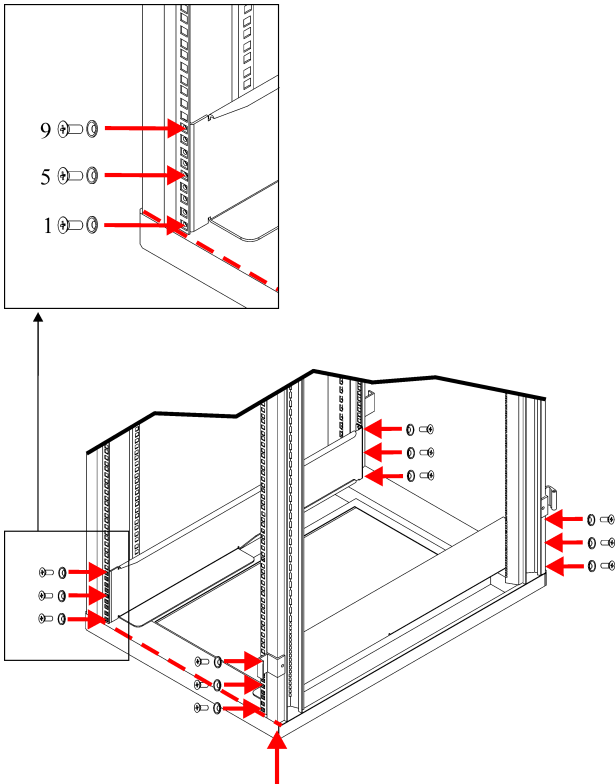

Bottom of UPS



4. Slide the UPS frame into the rack.

	Two people are required to lift, move, and install the UPS due to its weight.
--	---

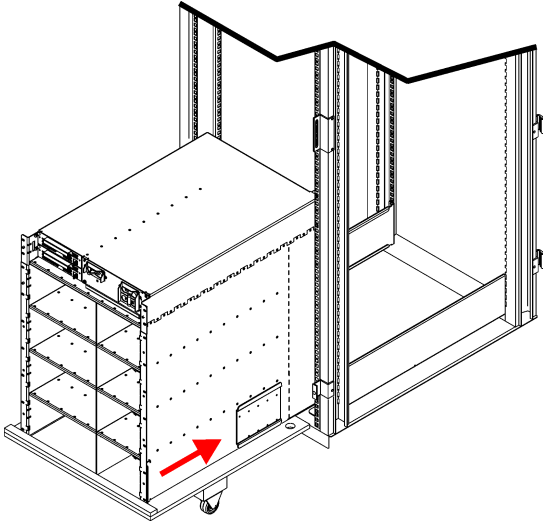

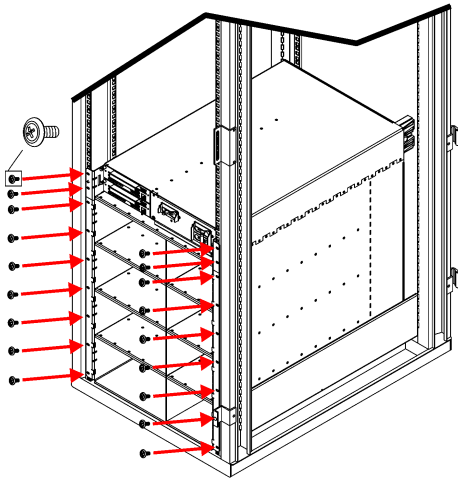

# CHAPTER 4: INSTALLATION



5. Secure the UPS frame in the rack.

Wiring the UPS

	<ul style="list-style-type: none"> <li>• Verify that all branch circuit (mains) and low voltage (control) circuits are de-energized, and locked out before installing cables or making connections, whether in the junction box or to the UPS.</li> <li>• Verify that the battery modules are not installed.</li> </ul>
	<p>Do not install battery modules until you are ready to power up the UPS. Batteries can be permanently damaged if loaded prematurely.</p>
	<ul style="list-style-type: none"> <li>• Check national and local codes before wiring.</li> <li>• Wiring by a qualified electrician is required.</li> <li>• Select wire size and connectors according to national and local codes.</li> <li>• Use flexible metal conduit to make maintenance and service easier.</li> </ul>

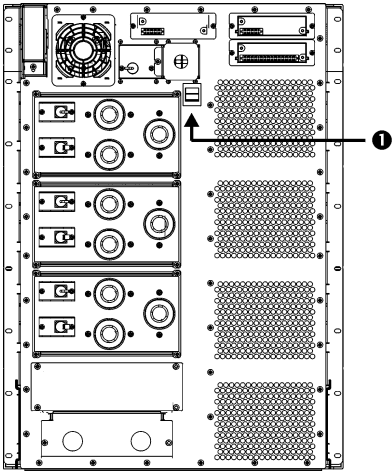

1. Set the input selection switch **1** according to the table shown below.

Table 4: Power Cord Ratings

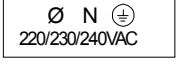
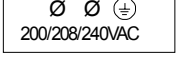
	Switch Setting
<b>North America and 208/240V (Ø- Ø -G)</b>	
<b>Europe and 230V (Ø- N -G)</b>	
<b>Japan and 200 V (Ø- Ø -G)</b>	

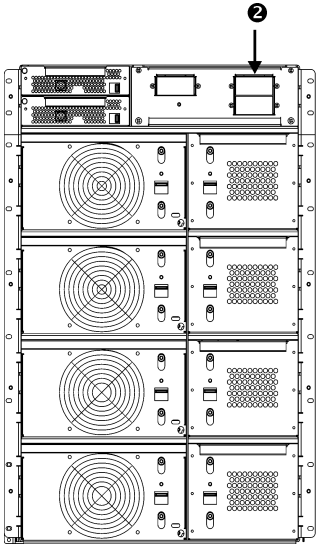

2. Make sure the input circuit breaker **2** is in the OFF position.

## CHAPTER 4: INSTALLATION

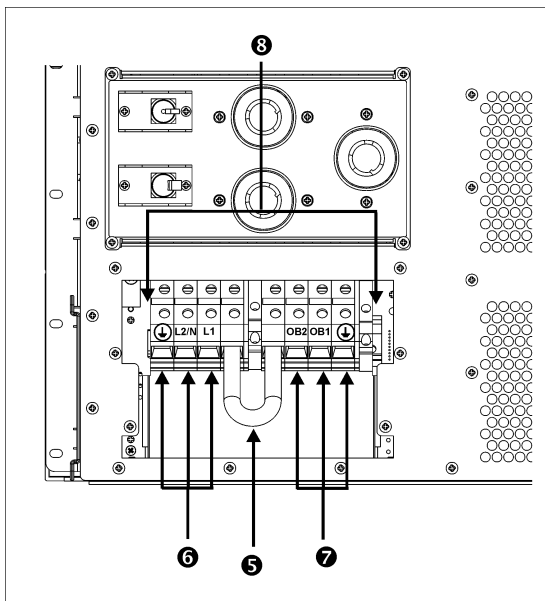
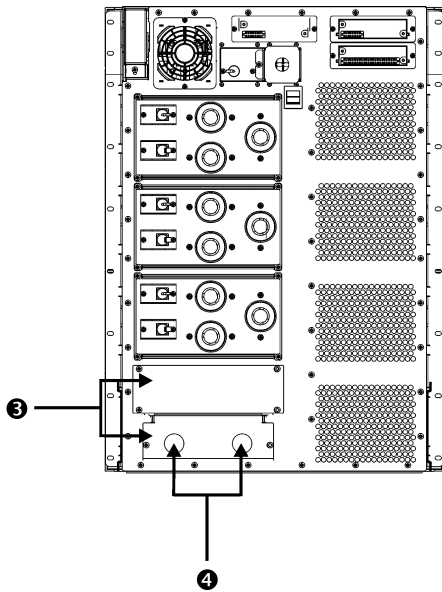

3. Remove the input-wiring access panels ③.
4. Remove the input and output (if applicable) knockouts ④.
5. Ensure that the battery jumper is installed between the terminal blocks ⑤. The battery jumper is used to disconnect batteries during shipment, if the battery modules are shipped installed.
6. Attach input ⑥ and if applicable, output ⑦ conduit and feed the wire through the holes on the wiring panel.
7. Connect the wires to the terminal block ③.
8. Inspect the connections.
9. With the input circuit breaker still OFF, turn ON the branch circuit (mains) and measure the L1-L2/N voltage. If the value does not match your branch voltage (200/208/220/230 or 240), check your wiring. Turn OFF the branch circuit (mains) and complete the installation.
10. Replace the access panels and fasten with the screws.
11. After the UPS is connected to the branch circuit (mains), install the three (3) "Isolate UPS before working on this circuit" labels at all of the buildings branch circuit (mains) disconnect panels.

# CHAPTER 4: INSTALLATION

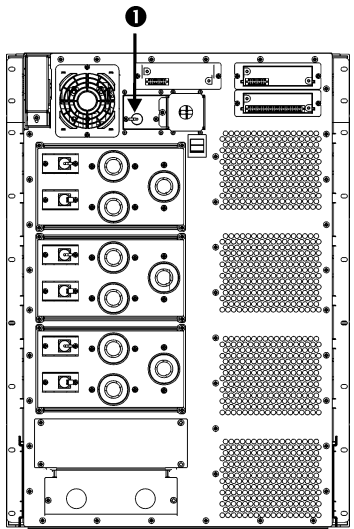

12. If required, connect the Remote Emergency Power Off (REPO). Check national and local codes before wiring. The output power can be disabled in an emergency by closing a switch connected to the REPO. You must physically reset the system enable switch on the front of the UPS to restart the unit.

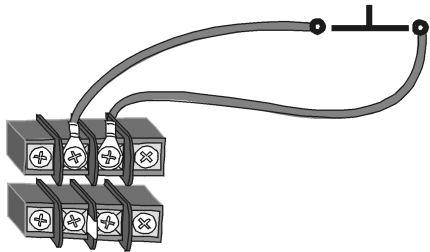

Option 1: Internally Powered (with Jumper Cable)

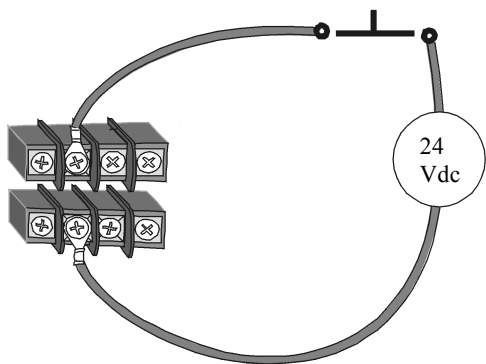

Option 2: Externally Powered (no Jumper Cable)

- The REPO circuit is considered a Class 2 (UL and CSA standards) and SELV (IEC standard) circuit.
- **Class 2 Circuit:** Used in North America by UL and CSA. It is defined in the National Electrical Code (NFPA 70, Article 725) and in the Canadian Electrical Code (C22.1, Section 16).
- **SELV Circuit:** Used in Europe by IEC; acronym for "safety extra low voltage." A SELV circuit is isolated from primary circuitry through an isolating transformer and designed so that under normal conditions, the voltage is limited to 42.4 V peak or 60 V dc
- Both Class 2 and SELV circuits must be isolated from all primary circuitry. Do not connect any circuit to the REPO terminal block unless it can be confirmed that the circuit is SELV or Class 2. If there is a question, use a contact closure switch.
- Use one of the following cable types to connect the UPS to the EPO switch:
  - CL2: Class 2 cable for general use.
  - CL2P: Plenum cable for use in ducts, plenums, and other spaces used for environmental air.
  - CL2R: Riser cable for use in a vertical run in a shaft of from floor to floor.
  - CLEX: Limited use cable for use in dwellings and for use in raceways.
- For installation in Canada: Use only CSA Certified, type ELC (extra-low voltage control cable).
- Wiring by a qualified electrician is required.

- Connect using Option 1 if internally powered.
- Connect using Option 2 if externally powered.

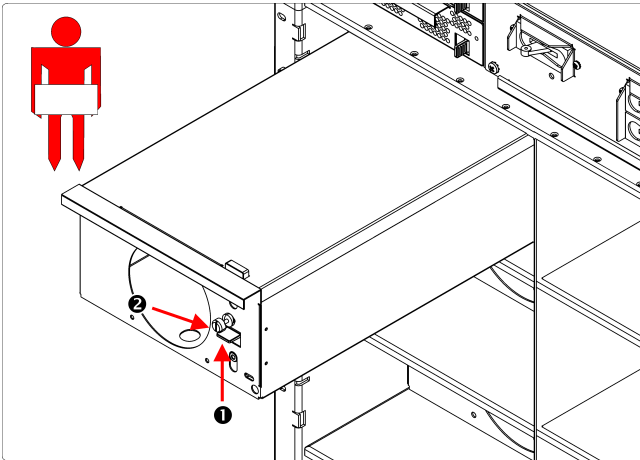

## CHAPTER 4: INSTALLATION

### Completing the Installation

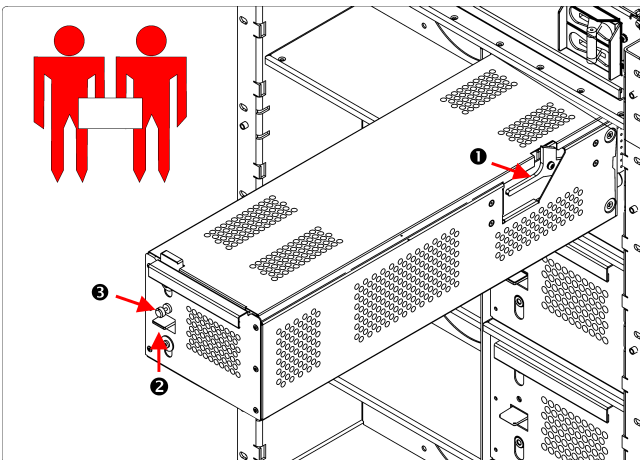

1. Install all power modules. Power modules can be installed in any slot on the left side.
  - Slide the power module into the frame.
  - Slide the latch **1** up and tighten the captive screw **2**.



	Two people are required to lift, move, install, or remove battery modules due to its weight.
	Do not install battery modules until you are ready to power up the UPS. Batteries can be permanently damaged if loaded prematurely.

2. Install all battery modules on the right side.
  - Slide the battery module into the frame until the safety latch **1** engages.
  - Slide the latch **2** up and tighten the captive screw **3**.

## CHAPTER 4: INSTALLATION

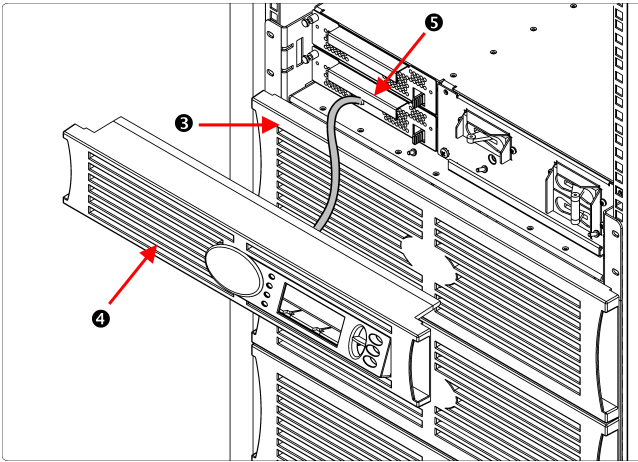

Blank cover plates must be installed over slots that do not contain battery or power modules.

3. Install the bezels ③.
4. Install the PowerView Display ④.
  - Connect the cable to the Main Intelligence Module ⑤ (MIM).
  - Align the tabs on the sides of the bezel with the slots on the front of the UPS frame and gently snap it into place.

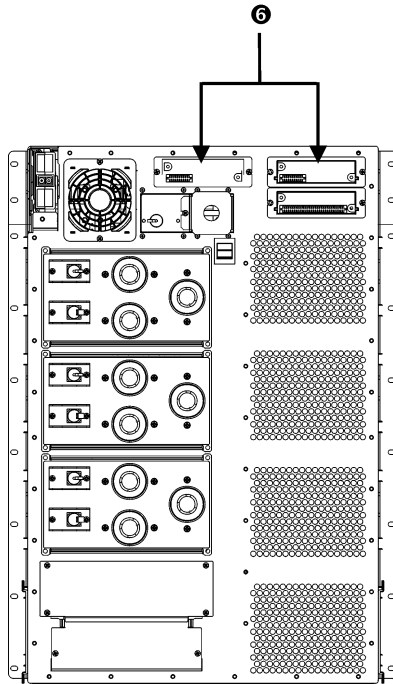

5. Install and connect any Smart Slot accessory in the appropriate accessory port ⑥.  
See the APC website at <http://www.apc.com> for available accessories. Refer to the accessory manual for installation and setup information.

## CHAPTER 4: INSTALLATION

### Connecting Load Equipment to the UPS

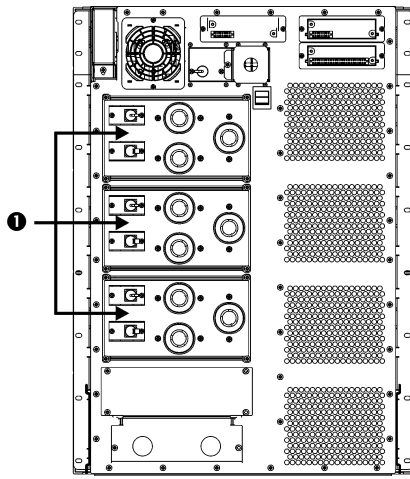

SYPD3

1. Plug all load equipment into PDU receptacles **1**.
2. Ensure that all PDU circuit breakers are turned ON. Refer to Table 2 on page 8 for additional information.

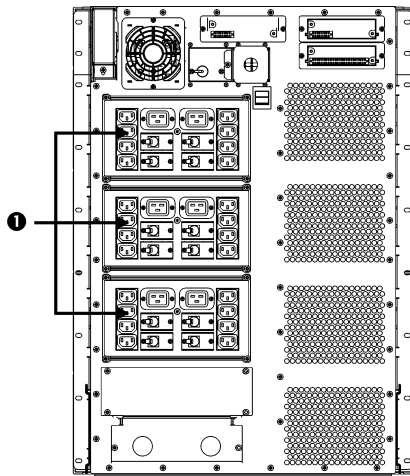

SYPD4



### ***Final Installation Checklist***

- ❑ Turn OFF or disconnect the load equipment.
- ❑ Verify the Input Voltage Selection switch setting.
- ❑ Ensure that the system is securely mounted in rack.
- ❑ Ensure that all modules (power, battery, and intelligence) are fully installed.
- ❑ Check that the PowerView is connected to the Main Intelligence Module (MIM).
- ❑ Verify that branch circuit (mains) voltage is properly connected to the terminal block.
- ❑ Ensure that the input cord is connected.
- ❑ Turn ON the branch circuit (mains).
- ❑ Turn ON the Input Circuit Breaker and System Enable switches.

The system will make some clicking sounds as it powers up, and may display fault messages on the PowerView display. Disregard the messages at this time. Press the 'Esc' button until the Monitoring screen is displayed.

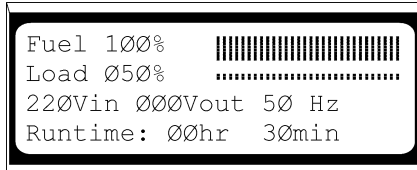

- ❑ Verify that the input voltage,  $V_{in}$ , matches your branch circuit (mains) voltage. The output voltage,  $V_{out}$ , should be zero.
- ❑ Switch the Maintenance Bypass ON.
- ❑ Disregard any LED indicators or messages on the PowerView. Press the 'Esc' button until the monitoring screen is displayed.
- ❑ Verify that the input voltage,  $V_{in}$ , and the output voltage,  $V_{out}$ , match your branch circuit (mains) voltage.
- ❑ Test the REPO switch. The System Enable switch should physically move to the Standby position, and the system should shut down completely.
- ❑ If all prior checks are completed, the installation is successful. Turn OFF the Input Circuit Breaker, System Enable, and Maintenance Bypass switches.

## CHAPTER 4: INSTALLATION

### Post Installation Procedures

---

This section contains information on how to replace battery, power, and intelligence modules.

#### Replacing Battery Modules

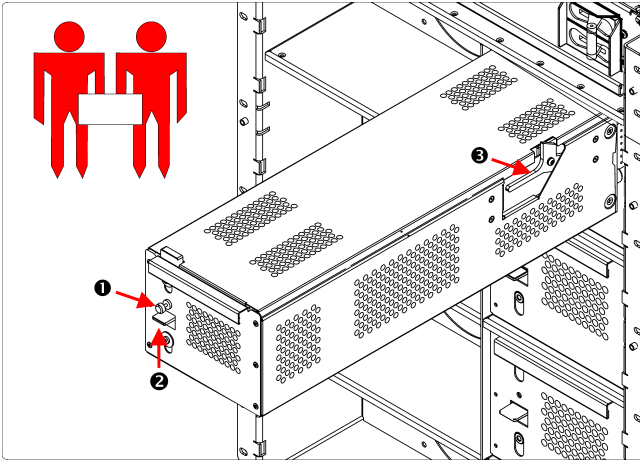

Two people are required to lift, move, install, or remove battery modules due to its weight.

1. Loosen the captive screw **1**, and slide the latch **2** down.
2. Slide the battery module until the safety interlock **3** engages.
3. Depress the safety interlock and lift the module out.
4. Slide the new battery module into the frame.
5. Slide the latch **2** up and tighten the captive screw **1**.

#### Replacing Power Modules

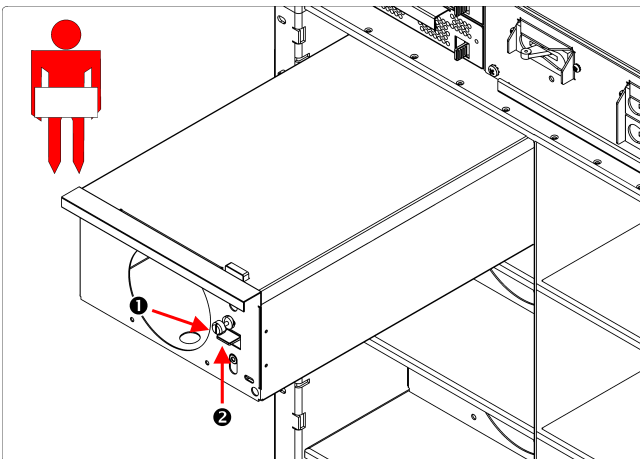

1. Loosen the captive screw **1**.
2. While holding the door latch **2** down, slide the power module out of the frame.
3. Slide the new power module into the frame.
4. Slide the latch **2** up and tighten the captive screw **1**.

***Replacing Intelligence Modules***

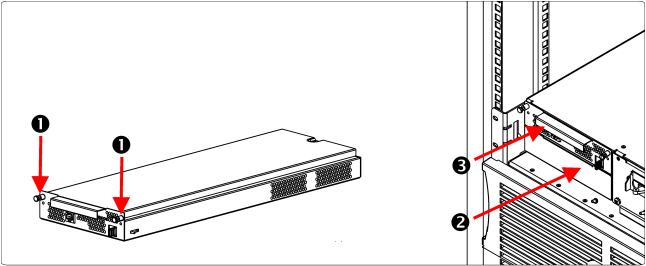

- 1. Loosen captive retaining screws ❶.
- 2. While holding retaining latch, remove the Main Intelligence Module (MIM) ❷ or Redundant Intelligence Module (RIM) ❸
- 3. Slide new MIM or RIM module into the frame.
- 4. Tighten the captive retaining screws ❶.

**CHAPTER 4: INSTALLATION**

## UPS Specifications

This section contains operation, input, output, physical, and compliance specifications for the UPS.

<b>Operational Specifications</b>	
System	Power Array with hot-swappable modules that are redundant, scalable, self-diagnosing, and fault-tolerant
Topology	On-line, double conversion with input power factor correction
Power Capacity	4 –16 kVA N, 12 kVA N+1
Battery Type	Hot-swappable, sealed, maintenance-free, lead acid, 3 – 5 years life
Battery Charger	Automatic float, equalized high frequency PWM charger
Battery Recharge Time	< 4 hours with standard supplied packs in the frame
Extended Battery Option	Yes
Ambient Temperature	0 – 40 °C
Relative Humidity	< 95% non-condensing
Elevation	0 – 10,000 ft (3,000 mm)
<b>Input Specifications</b>	
Nominal Input Voltage	200, 208, 220, 230, 240 Vac; 60 or 50 Hz, 1 phase, 3 wire
Input Voltage Range	155 to 276 Vac with batteries charging & supporting full load
Input Frequency Range	47 – 63 Hz
Input Power Factor	Approximately. 0.98 @ full load
Input Current THD	Approximately. 6% @ full load
Input Inrush Current	Maximum 150% of full load current
Input Generator Sizing	1.5 x UPS capacity

## CHAPTER 5: SPECIFICATIONS

<b>Output Specifications</b>	
Nominal Output Voltage	200, 208, 220, 230, 240 Vac; 50 or 60 Hz, 1 phase, 3 wire
Output Power kVA	4 – 16 kVA
Output Power kW	2.8 – 11.2 kW
Load Power Factor	0 – 1
Output Frequency	60 or 50 Hz nominal
Output Voltage Regulation Steady State	< ± 3% for no load to full load, min ac input to max ac, min dc to max dc, linear or non-linear load or any combination
Output Voltage Regulation Transient/Dynamic	< ± 5% for 100% load application or removal, linear or non-linear load
Recovery Time	< 10 milliseconds (i.e. half cycle to steady state)
Total Harmonic Distortion	< 2% for linear loads; < 5% for non-linear loads.
Load Crest Factor Supported	< 5% for 100% non-linear loads up to 5:1
Overload Capacity	130% for 10 minutes. With N+1
Efficiency	Approximately 90% @ full load—linear or non-linear loads
<b>Physical Specifications</b>	
Audible Noise	< 62 dBA
Dimensions (H x W x D)	26.1 in x 18.9 in x 27.8 in (with bezel) (66.3 cm x 48.0 cm x 70.6 cm)
Weight – Fully Loaded	Approximately 557 lb (133.6 kg)
Heat Dissipation (Full Load)	8811 BTUs typical – Batteries charged 9664 BTUs typical – Batteries charging
<b>Compliance Specifications</b>	
VDE-GS Certifications	EN 60950, EN 50091-1-1, EN 50091-2, IEC 60950, IEC 146-4, VDE 0558 and VDE 0805
UL Listing	UL 1778
CSA Certification	CSA 107.1

# APC Symmetra RM

## Operation Manual

English

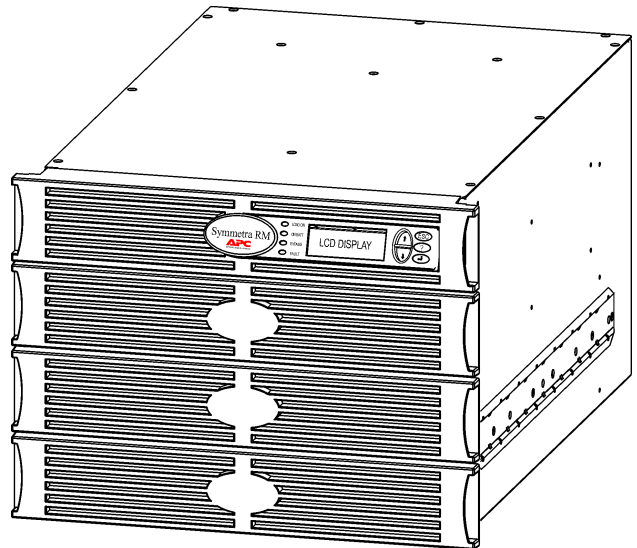
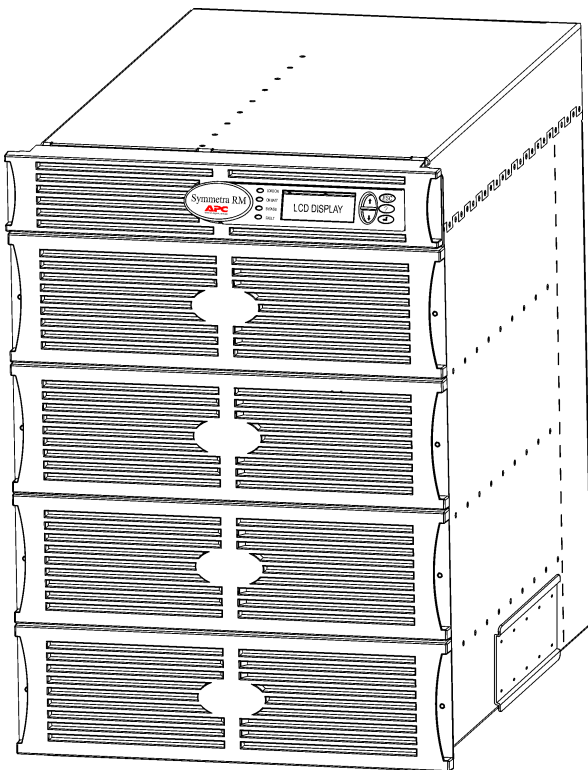





# TABLE OF CONTENTS

## APC Contact Numbers and Support

Visit the APC Web site for contact numbers and support at <http://www.apc.com/support>.

## Battery Replacements Kits and Battery Recycling

See your dealer or visit the APC web site at <http://www.apc.com> for information on battery replacement kits and battery recycling. If returning used batteries to APC for recycling, ship used batteries in the battery replacement packing material.

<b>Chapter 1: Overview</b> .....	<b>1</b>
PowerView .....	1
Navigation.....	1
Functions.....	2
<b>Chapter 2: Getting Started</b> .....	<b>3</b>
Turning on the UPS .....	3
Powering Up the Load Equipment .....	4
Powering Down the Load Equipment.....	5
Bypass Operation.....	6
Language Setting .....	7
<b>Chapter 3: Menu Commands</b> .....	<b>11</b>
Command Reference .....	11
Accessories Menu .....	11
Control Menu .....	11
Display Menu.....	12
Diagnostics Menu .....	13
Help Menu .....	13
Logging Menu.....	13
Status Menu .....	14
Setup Menu .....	15
<b>Chapter 4: Messages</b> .....	<b>17</b>
Troubleshooting.....	17
<b>Chapter 5: Maintenance</b> .....	<b>23</b>
Service .....	23

## TABLE OF CONTENTS

# PowerView

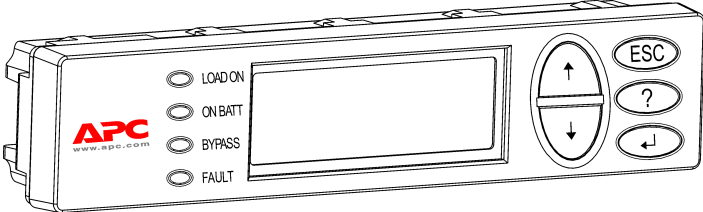

Figure 1: Typical PowerView Display

This manual contains information on how to operate the UPS using the PowerView user interface.

PowerView provides the ability to control, configure, and monitor the UPS.

## Navigation

Eight (8) PowerView Display menus allow you to perform functions and commands.

Menu	Description
Control	Provides power control commands, such as Load ON and Load OFF.
Status	Displays information regarding load, battery and power modules, voltage and electrical current.
Setup	Allows the user to customize the UPS functionality.
Accessories	Allows monitoring of installed APC accessories, if they are present.
Logging	Provides ability to log system events.
Display	Allows configuration of PowerView display settings.
Diagnostics	Provides detailed information useful in troubleshooting the system.
Help	Provides access to help information.

# CHAPTER 1: OVERVIEW

## Functions

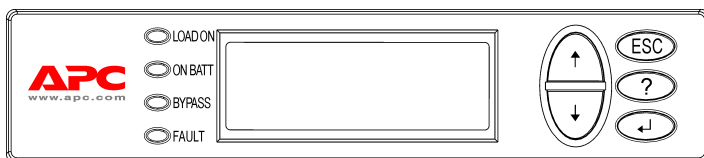

**Figure 2: Display Panel**

PowerView includes an alphanumeric display, navigation keys, status indicators, and an audible alarm.

The tables below describe the status indicators and how to navigate between PowerView menus.

Status Indicator	Color	Status
LOAD ON	Green	The UPS is supplying power to the load. It may be operating in any one of the following modes: On-Line, On-Battery, Command-Bypass, or Maintenance.
ON BATT	Yellow	A mains power failure has occurred, and the battery modules are supplying power to the load equipment.
BYPASS	Yellow	Power to the load is being supplied directly by the mains power source. The UPS is removed from the circuit.
FAULT	Red	The UPS has detected an internal fault condition. An alarm message will appear on the PowerView display.

Navigation Keys	Name	Sound	Function
↑	Up	Short beep	Moves the selection arrow upward.
↓	Down	Short beep	Moves the selection arrow downward.
ESC	Escape	Short beep	Exits the current screen and returns to the previous screen.  Programming mode only: when pressed until a short beep (up to one second) occurs, it exits the programming mode.
?	Help	Short beep	Opens context-sensitive help.
↵	Enter	Short beep	Opens the selected menu item or setting.
ESC + ? + ↵	Escape + Help + Enter	Two short beeps	When pressed simultaneously for about 1 second, resets the PowerView RM interface.
		One long beep	When pressed simultaneously for about 3 seconds, puts the interface in programming mode for installing new language program files.

## Turning on the UPS

Follow the steps below to turn ON the UPS.

❶

```
PowerView RM
Rev: A English

Please wait...
```

❷

```
Fuel 100% ██████████
Load 000% -----
220Vin 000Vout 60Hz
Runtime: 00hr 30min
```

	<ul style="list-style-type: none"> <li>• The factory default Monitoring screen is shown. Your actual screen may vary.</li> <li>• After the PowerView has been inactive for 10 minutes (user settable), the display will revert to the Monitoring screen.</li> </ul>
---	---

❸

```
>Control      Logging
Status       Display
Setup        Diags
Accessories  Help
```

1. Ensure that branch (mains) power is supplied to the system.
2. Check to make sure that the input circuit breaker on the UPS is turned ON.
3. Turn the System Enable switch ON. The Startup screen ❶ appears on the LCD. After initialization, the Monitoring Screen ❷ appears, providing a concise view of key operating parameters.

Fuel	Percentage of battery capacity available
Load	Percentage of power capacity used
Vin	Input voltage
Vout	Output Voltage
Hz	Output Frequency
Runtime	Runtime expected based on battery capacity and connected load

4. At the Monitoring screen, press any navigation key to open the Main Menu ❸. This menu contains items that access eight submenus.
5. To open a submenu, move the selection arrow to its item and press the ENTER key.

## CHAPTER 2: GETTING STARTED

### Powering Up the Load Equipment

---

Follow the steps below to turn ON the output of the UPS and power the load equipment.

❶

```
>Control      Logging
   Status      Display
   Setup       Diags
   Accessories Help
```

❷

```
>Turn Load On
   Do Self Test
   Simulate Power Fail
   Graceful Reboot
```

❸

```
Confirm:
   Turn UPS ON
   NO, ABORT
> YES, Turn UPS ON
```

❹

```
UPS HAS BEEN
COMMANDED TO TURN
LOAD POWER ON
```

❺

```
UPS LOAD IS ON

Press any key...
```

1. Use 'ESC' to view to Main Menu ❶, and then select CONTROL.
2. Select the TURN LOAD ON ❷ command.
3. Confirm choice by selecting YES ❸.
4. You will hear some clicking sounds and see message ❹.
5. In approximately 30 seconds, you will see message ❺, and the green LOAD ON status indicator will be ON.  
The output is now ON and fully protecting the load equipment.

## Powering Down the Load Equipment

Follow the steps below to turn OFF the output of the UPS and power down the load equipment.

❶

```
>Control      Logging
   Status      Display
   Setup       Diags
   Accessories Help
```

❷

```
>Turn Load Off
   Do Self Test
   Simulate Power Fail
   Graceful Reboot
```

❸

```
Confirm:
   Turn UPS OFF
   NO, ABORT
> YES, Turn UPS OFF
```

❹

```
UPS HAS BEEN
COMMANDED TO TURN
LOAD POWER OFF
```

❺

```
UPS LOAD IS OFF

Press any key...
```

1. Use 'ESC' to view to Main Menu ❶, and then select CONTROL.
2. Select the TURN LOAD OFF ❷ command.
3. Confirm choice by selecting YES ❸.
4. You will hear some clicking sounds and see message ❹.
5. In approximately 30 seconds, you will see message ❺, and the green LOAD ON status indicator will be OFF.  
The output is now OFF.
6. To fully power down the UPS, turn OFF the System Enable switch, and open the input circuit breaker.



Do not install battery modules until you are ready to power up the UPS. Batteries can be permanently damaged if loaded prematurely.

## CHAPTER 2: GETTING STARTED

### Bypass Operation

---

In addition to the automatic bypass, a maintenance bypass switch is provided with the UPS. Placing this switch in bypass mode connects the load equipment to the branch circuit, even if the UPS is turned OFF.



When using the maintenance bypass, the input circuit breaker must be ON, or power will not be supplied to the Load screen.

Follow the steps below to connect directly to the branch circuit (mains) via the automatic bypass.

❶

```
>Control      Logging
Status        Display
Setup         Diags
Accessories   Help
```

1. Use 'ESC' to view to Main Menu ❶, and then select CONTROL.

2. Select the UPS INTO BYPASS ❷ command.

3. Confirm choice by selecting YES ❸.

4. You will see message ❹. In addition, the green LOAD ON and yellow BYPASS status indicators will be ON.

❷

```
>Turn Load Off
Do Self Test
Simulate Power Fail
Graceful Reboot ↓
```

```
Graceful Turn Off
Start Runtime Cal
>UPS into Bypass
```

❸

```
Confirm:
  UPS into Bypass
NO, ABORT
>YES,UPS into Bypass
```

❹

```
UPS IS BYPASSED

Press any key...
```



### Language Setting

---

The factory default language of the user interface is English. You can change the language by downloading new firmware into the PowerView. French, German, Italian, and Spanish are available on the enclosed CD. Visit the APC web site at <http://www.apc.com> for multilingual product documentation and firmware language support.

To change the user interface language, perform the following steps.

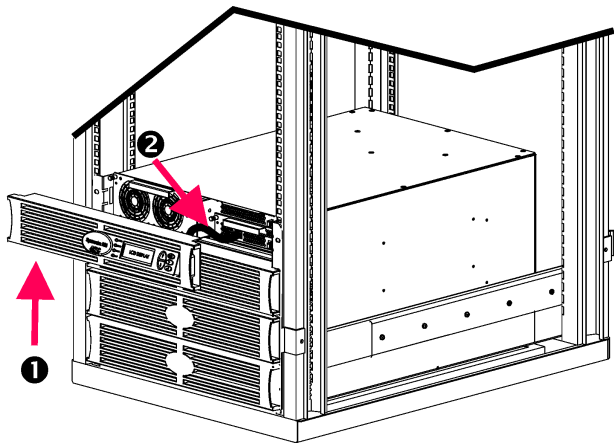

1. Remove the PowerView Display bezel ❶ from the front of the UPS.
2. Disconnect the UPS cable ❷ from the RJ-45 port on the PowerView.

**Figure 3: Shown connected to Symmetra RM 2-6 kVA**

## CHAPTER 2: GETTING STARTED

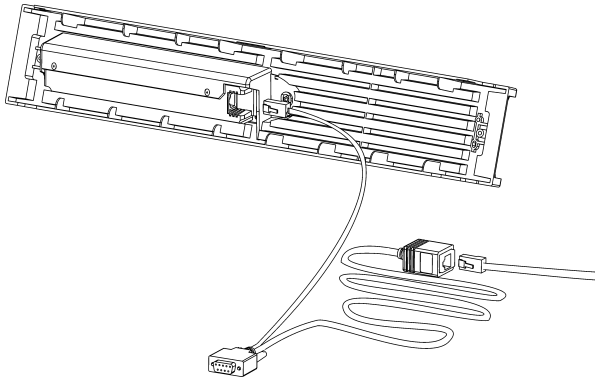

**Figure 4: Typical Programming Cable**

3. Connect the programming cable (included, APC part number 940-0082) between the PowerView and the UPS cable.

- Attach the RJ-45 connector to the port on the rear of the PowerView.
- Connect the female DB-9 connector of the programming cable to a serial port on the computer.

The downloading computer must have access to the files on the CD provided either with the UPS or to the APC Web site (<http://www.apc.com>).

- Attach the UPS cable to the female RJ-45 connector on the programming cable.

4. Locate the language program file to be downloaded into the UPS.

Each language program file appears on the CD under the folder of its language (français, español, etc.) with a **.bin** extension. Program files for additional language support or code updates may be available on the APC Web site.

5. Place the PowerView in programming mode by pressing simultaneously the three keys on the right (ESCAPE, HELP, and ENTER) for about three seconds, until the PowerView emits a long beep.

- The LCD will display the Programming screen.
- To leave the Programming screen before starting a file transfer (step 6), press ESC until it beeps (about one second).

## CHAPTER 2: GETTING STARTED

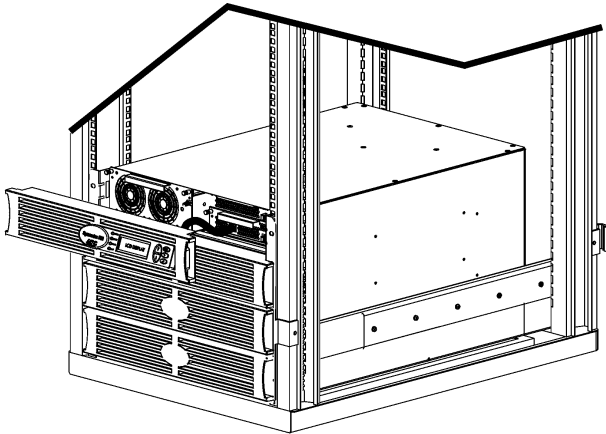

**Figure 5: Shown connected to Symmetra RM 2-6 kVA**

6. Start HyperTerminal or another terminal emulation program on the computer.
  - Set the communication parameters to 8 bits, no parity, no flow control, 1 stop bit, and 19,200 bps.
  - After establishing a connection, use the Xmodem protocol to transfer the language program file from the CD or your download folder to PowerView.
  - When the file transfer is complete, the PowerView will reset itself and display the Startup screen in the new language.
7. If the file transfer fails, PowerView will reset itself. Retry the file transfer by repeating steps 4 and 5.
8. Quit the terminal session.
  - Disconnect the programming cable and reconnect the UPS cable to the PowerView.
9. Align the tabs on the size of the PowerView Display bezel with the slots on the front of the UPS frame and gently snap it into place.

## CHAPTER 2: GETTING STARTED

## Command Reference

---

The following sections describe the details of each command. Commands are organized according to the menu hierarchy in the PowerView.

### ***Accessories Menu***

The Accessories menu allows you to monitor APC accessories if they are installed. Note that the PowerView must be connected to the computer interface port at the back of the UPS frame in order to monitor internal accessories.

### ***Control Menu***

Use the Control menu and its submenus to control how power flows to and from the UPS.

<b>Menu Item</b>	<b>Function</b>
Turn Load On/Off	Controls the delivery of output power to connected equipment.
Do Self Test	Initiates a system of self-testing and diagnostics. An error message is displayed when a problem is detected.
Simulate Power Fail(ure)	Simulates a power failure/return to test server's recognition of failure event.
Graceful Reboot	Initiates a signal for the server to shutdown. After user-defined "Low-Battery Duration" plus "Shutdown Delay," the output power is switched off for the duration of the user-defined "Return Delay." Then the output power is switched on again. See Setup-Shutdown to set these time delays.  PowerChute software must be used on the server for it to be properly shutdown.
Graceful Turn Off	Initiates a signal for the server to shut down. After the user-defined "Low-Battery Duration" plus "Shutdown Delay," the output power is switched off. Use the Setup-Shutdown menu to set these times.  PowerChute software must be used on the server for it to be properly shutdown.
Start/Stop Runtime Cal(ibration)	Calculates an accurate battery runtime measurement. Delivers load output power from battery source. Discharges battery to 50% of capacity. Battery capacity must be at 100% to execute this test.
UPS into/out of Bypass	Controls the bypass function. When in the bypass mode, power is delivered directly from utility source to load equipment.

## CHAPTER 3: MENU COMMANDS

### *Display Menu*

The Display menu lets the user customize the PowerView display.

Display		Function	Options
Date/Time		Sets the correct date and time.	dd:mmm:yyyy
Password		Protects against unauthorized configuration changes.	
	Password	Sets a password.	Valid characters include A–Z, 0–9; Type ‘_’ to complete
	Timeout	Sets the inactivity timer.	1, 2, 5, 10(default), or 30 minutes, 1, 2, or 4 Hours, or Forever
	Invalidate	Puts password into effect. Prevents unauthorized changes to the UPS configuration.	
Information		Displays PowerView model number, serial number, date of manufacture, and revision information.	
Beeper		Sets audible alarm (beeper) criteria.	
	At UPS	Not used with the UPS.	
	At Display	Sets parameters for the audible alarm in the PowerView.	Power Failure, Power Failure +30 seconds, Low Battery, Never
	Volume	Sets audible alarm volume.	Off, Low(default), Medium, High
	Click	Sets sound when pressing display buttons.	On(default), Off
Contrast		Sets LCD screen contrast.	1, 2, 3, 4, 5
Configure		Customizes the information displayed on the Startup screen.	Use factory defaults when possible.

### ***Diagnostics Menu***

The Diagnostics menu provides information for use in troubleshooting.

Menu Item	Function
Fault and Diagnostics	Displays current system fault and diagnostic information of that fault.
(Main) Intelligence Module	Displays detailed intelligence module status and information.
Redundant Intelligence Module	Displays detailed redundant intelligence module status and information.
Power Modules	Displays detailed power module status and information.
Batteries	Displays detailed battery module status and information.

### ***Help Menu***

To access PowerView online help screens, press the SCROLL UP and SCROLL DOWN keys simultaneously to access context sensitive help.

### ***Logging Menu***

The Logging menu lets you customize the UPS log.

Menu Item	Function								
View Log	Logs the most recent 64 events. Point to an entry and press the ENTER key for more information on that event.								
View Statistics	Records the total number of transfers to battery, low battery, faults, and on-battery runtime events.								
Configure Logging	Allows different types of events to be included or excluded from the log. Event types include Power Events, UPS Controls, UPS Faults, and User Activity.								
<table border="1" style="width: 100%; border-collapse: collapse;"> <tr> <td style="width: 20px;"></td> <td>Power Events</td> </tr> <tr> <td></td> <td>UPS Controls</td> </tr> <tr> <td></td> <td>UPS Faults</td> </tr> <tr> <td></td> <td>User Activity</td> </tr> </table>		Power Events		UPS Controls		UPS Faults		User Activity	On (default), Off
	Power Events								
	UPS Controls								
	UPS Faults								
	User Activity								
<table border="1" style="width: 100%; border-collapse: collapse;"> <tr> <td style="width: 20px;"></td> <td>UPS Control Events</td> </tr> <tr> <td></td> <td>User Activities</td> </tr> <tr> <td></td> <td>UPS Fault Events</td> </tr> <tr> <td></td> <td>MeasureUPS Events</td> </tr> </table>		UPS Control Events		User Activities		UPS Fault Events		MeasureUPS Events	
	UPS Control Events								
	User Activities								
	UPS Fault Events								
	MeasureUPS Events								

## CHAPTER 3: MENU COMMANDS

### *Logging Menu (continued)*

Menu Item		Function
List Event Groups		Lists the specific events in each group.
	Power Events	
	UPS Control Events	
	User Activities	
	UPS Fault Events	
	MeasureUPS Events	
Clear Log		Clears the view log. Does not clear the active event lists.

### *Status Menu*

The Status menu displays information regarding load, battery and power modules, voltage, and electrical current.

Menu Item	Function
Ø Vin Vout Iout	Displays input voltage, output voltage, and output current information.
% load assuming no redundancy	Compares the current load to the total capacity of all power modules.
% load allowing for n+ redundancy	Compares the current load to the total capacity of all power modules except the power modules that are set aside by the "Fault Tolerance" alarm threshold. For example, if there are four power modules installed, and the fault tolerance alarm threshold is set to "1," this percentage of load uses only 3 power modules for the calculation. See Setup-Alarms to set the redundancy level.
Frequencies	Displays the measured input and output frequencies.
Battery Status Screen	Displays battery module source capacity, runtime, and status information.
Power Module Status Screen	Displays power module source capacity, fault tolerance, and status information.
Alarm Thresholds Status Screen	Displays the user-defined alarm settings. See Setup-Alarms to set these alarm thresholds.
Miscellaneous Status Screen	Displays the summary result Self Test, Last System Transfer, Operating Mode, and status of Intelligence and redundant intelligence modules.



## CHAPTER 3: MENU COMMANDS

### Setup Menu

The Setup menu lets the user customize the UPS functionality.

Menu Item		Function	Options
Shutdown		Sets the shutdown parameters in the event of a utility power failure.	None
	Low Batt(ery) Dur(ation)	Sets the number of minutes an audible alarm sounds before the UPS shuts down due to battery exhaustion.	2(default), 5, 7, 10, 12, 15, 18, or 20 minutes
	Shutdown Delay	Sets the additional runtime for computer issuing shutdown command if it needs additional time to shut itself down.	0, 20(default), 60, 120, 240, 480, 720, or 960 seconds
	Return Delay	Sets the delay interval that allows utility power to stabilize before the system goes back online after a utility power failure.	0(default), 20, 60, 120, 240, 480, 720, or 960 seconds
	Return Battery Capacity	Sets the minimum battery capacity necessary before repowering the load when returning from an extended utility power failure.	0(default), 15, 25, 35, 50, 60, 75, or 90 seconds
Defaults		Sets all settings to factory defaults.	
Output Freq(uecy)		The UPS output will phase lock to the input within this range.	50 ± 3 Hz, 60 Hz ± 3 Hz, Full Range Tracking

## CHAPTER 3: MENU COMMANDS

### Setup Menu (continued)

Menu Item		Function	Options
Alarms		Sets the alarm thresholds.	None
	Redundancy	An audible alarm sounds if the redundancy falls below this level.	0(default), 1, or 2
	Load	An audible alarm sounds when the load exceeds this limit. (Upper value is limited by the maximum power of the UPS.)	Never(default), 1, 2, 3, 4, 5, 6, 7, 8, 9, 10, or 12 kVA
	Runtime	An audible alarm sounds if the available runtime falls below this level (Hours:min).	0:0(default),5m, 10m, 15m, 30m, 45m,1h, 2h, 3h, 4h, 5h, 6h, 7h, or 8h
Bypass		In the unlikely event that both the UPS fails and the input voltage or line frequency is outside of normal range, this option lets you choose to go into Bypass mode or drop the load.	Go to Bypass or Drop Load
Copy		Not used with this UPS.	
Other		Remaining user-defined settings.	
	Self Test	The UPS can automatically test itself at this user-specified interval.	At Power On, 7 days, 14 days(default) , or Disabled
	UPS ID	Assigns an eight-character text string to a system.	
	Output	Sets output voltage. Selection depends upon system configuration.	200V, 208V, 220V, 230V, or 240V
	Vout Reporting	Reports the most significant output voltage.	Auto

## Troubleshooting

The PowerView reports various messages on the display, including alarm status and changes in system configuration. This section lists all the PowerView display messages, what each means, and an appropriate corrective action.

Contact APC Technical Support Staff for assistance with complex UPS problems. Refer to the APC Web site at <http://www.apc.com/support> for a location near you.

More than one of these messages may occur at one time. If this happens, be sure to review all of the messages for a better understanding of the system condition.

	PowerView Message	Meaning	Corrective Action
Start-Up	#Pwr modules changed since last ON.	At least one power module has been added or removed from the UPS since the last time the Pwr ON command was issued.	No corrective action necessary. Proceed with the startup.
	#Batteries changed since last ON.	At least one battery module has been added or removed from the UPS since the last time the Pwr ON command was issued.	
	No Redundant Intelligence Module.	There is no RIM installed.	Proceed with the startup or abort the startup and install a RIM.  <i>Note: Without a functioning RIM, there is no redundancy in the event of a MIM failure.</i>
	Batt capacity less than Return Batt Cap.	The battery capacity of the UPS is less than the user specified minimum battery capacity required to turn on the load.	Option 1: Abort the startup and allow batteries to recharge.  Option 2: Continue startup, with less than minimum battery capacity.
	Input Freq outside configured range.	The input frequency to the UPS is outside the configured range. The output frequency will not synchronize with the input frequency. Normal bypass is not available. The system will start on-battery.	Option 1: Improve the frequency of the incoming voltage.  Option 2: Widen the range of the acceptable incoming frequency with the PowerView. (Startup>Setup>OuputFreq)  Option 3: Proceed with startup. Normal bypass is not available and system may start on battery power.

## CHAPTER 4: MESSAGES

	PowerView Message	Meaning	Corrective Action
Start-Up (continued)	AC adequate for UPS but not for bypass.	The UPS will function on-line with the input voltage, but in the event that bypass is required, the input voltage is not adequate to power the load equipment.	Option 1: Improve the incoming voltage.  Option 2: Proceed with startup. Normal bypass is not available.
	Low/No AC input, startup on battery.	Input voltage is not adequate to start the UPS. If startup proceeds, the UPS will function from battery.	Option 1: Abort startup until acceptable input voltage is present.  Option 2: Proceed with startup. Battery will be discharged.
General Status	# of batteries increased.	At least one battery module has been added to the system.	No corrective action necessary.
	# of batteries decreased.	At least one battery has been removed from the system.	
	# of Pwr Modules increased.	At least one power module has been added from the system.	
	Intelligence Module inserted.	A MIM has been installed into the UPS.	
	Intelligence Module removed.	A MIM has been removed from the UPS.	
	Redundant Intelligence Module inserted.	A RIM has been installed into the UPS.	
	Redundant Intelligence Module removed.	A RIM has been removed from the UPS.	
	# of External Battery Cabinets increased.	At least one external battery cabinet has been connected to the frame.	
	# of External Battery Cabinets decreased.	At least one external battery cabinet has been disconnected from the UPS.	

## CHAPTER 4: MESSAGES

	PowerView Message	Meaning	Corrective Action
General Status	Redundancy Restored.	Power module redundancy loss occurred and was restored. Either additional modules have been installed or the load has been reduced.	No corrective action necessary.
	Load is No Longer above Alarm Threshold.	The load exceeded the load alarm threshold. The situation has been corrected because either the load decreased or the threshold was increased.	
	Min Runtime restored.	The system runtime dropped below the configured minimum runtime and was restored.  Either additional battery modules were installed, the existing battery modules were recharged, the load was reduced, or the threshold was raised.	
Module Failure	Bad Battery Module.	A battery module failed and requires replacement.	Refer to module replacement procedure SYMMETRA RM INSTALLATION MANUAL.
	Bad Power Module.	A power module failed and requires replacement.	
	Intelligence Module is installed and failed.	The MIM failed and requires replacement.	
	Redundant Intelligence Module is installed and failed.	The RIM failed and requires replacement.	
Threshold Alarm	Load is above kVA alarm threshold.	The load has exceeded the user specified load alarm threshold.	Option 1: Reduce the load.  Option 2: Use the PowerView interface to raise the alarm threshold.
	Redundancy has been lost.	The UPS no longer detects redundant power modules. Either power module(s) failed or the load increased.	Option 1: If possible, install additional power modules.  Option 2: Decrease the load.  Option 3: Disable the redundancy alarm by setting redundancy to zero. (Startup>Setup>Alarms>Redundancy>Zero)

## CHAPTER 4: MESSAGES

	PowerView Message	Meaning	Corrective Action
Threshold Alarm (continued)	Redundancy is below alarm threshold.	Actual power module redundancy has fallen below the user specified redundancy alarm threshold. Either power module(s) failed or the load has increased.	Option 1: If possible, install additional power modules.  Option 2: Decrease the load.  Option 3: Use the PowerView to decrease the redundancy alarm threshold. (Startup>Setup>Alarms>Redundancy)
	Runtime is below alarm threshold.	The predicted runtime is lower than the user specified for the minimum runtime alarm threshold. Either the battery capacity has decreased or the load increased.	Option 1: Allow the battery modules to recharge.  Option 2: If possible, increase the number of battery modules.  Option 3: Decrease the load.  Option 4: Use the PowerView to decrease the minimum runtime alarm threshold. (Startup>Setup>Alarms>Runtime)
Bypass	Bypass is not in range (either freq or voltage).	The frequency and/or voltage are out of acceptable range for bypass. This message occurs when the UPS is online and indicates that the bypass mode may not be available if required. The system may start on-battery.	Option 1: Decrease the sensitivity to input frequency. (Startup>Setup>OutputFreq)  Option 2: Correct input voltage to provide acceptable voltage and/or frequency.
	Bypass contactor stuck in bypass position.	The UPS is positioned in the bypass position and cannot go on-line.	Call your contract service provider or APC Technical Support.
	Bypass contactor stuck in on-line position.	The UPS is positioned in the on-line position and cannot go to bypass.	
	UPS in bypass due to internal fault.	The UPS has transferred to bypass mode because a fault has occurred.	
	UPS in bypass due to overload.	The load exceeded the system power capacity. The UPS has switched to bypass mode.	Option 1: Decrease the load.  Option 2: If possible, add power modules to the system.
	System is in Maintenance Bypass.	The UPS is in bypass because the maintenance bypass switch is in the On position.	No corrective action necessary.

## CHAPTER 4: MESSAGES

	PowerView Message	Meaning	Corrective Action
General Fault	On Battery.	The UPS is in the on-battery mode. The battery modules are being discharged.	No corrective action is necessary.  Note: Runtime is limited in duration. Prepare to shutdown the UPS and the load equipment, or restore incoming voltage.
	Need Bat Replacement.	One or more battery modules are in need of replacement.	Refer to module replacement procedure.
	UPS Fault.	A fault occurred in a power module. The UPS Fault message always occurs when there is a bad power module failure message.	Call your contract service provider or APC Technical Support.
	Shutdown or unable to transfer to Batt due to overload.	The UPS has shutdown because an overload occurred and bypass is not available.	Option 1: Reduce the load to eliminate overload.  Option 2: If possible, add power modules to eliminate overload.  Option 3: Replace failed power modules to eliminate overload.  Note: If bypass is not available because of a power failure, wait for power to be restored. If there is a utility problem, have it corrected.
	Load Shutdown from Bypass. Input Freq/Volts outside limits.	The UPS shut the load down while it was on bypass, because the input power went out of acceptable range.	Correct the input voltage problem.
	Fault, Battery Charger Failure.	The battery charger in one or more power module(s) failed.	Refer to module replacement procedure.
	Fault, Bypass Relay Malfunction.	The bypass relay has malfunctioned.	Call your contract service provider or APC Technical Support.
	Fault, Internal Temp exceeded normal limits.	The temperature of one or more battery modules is too hot.	Replace overheated module. Refer to module replacement procedure.

## CHAPTER 4: MESSAGES

	<b>PowerView Message</b>	<b>Meaning</b>	<b>Corrective Action</b>
General Fault (continued)	Input circuit breaker tripped open.	The input circuit breaker on the UPS tripped open. Input voltage is disconnected to the UPS.	Option 1: If this occurs in conjunction with an overload condition, decrease the load and reset the breaker.  Option 2: If no overload condition exists, reset breaker. If it trips open again, call your contract service provider or APC Technical Support.
	System level fan failed.	A cooling fan in the UPS frame failed.	Call your contract service provider or APC Technical Support.
	The Redundant Intelligence Module (RIM) is in control.	The MIM failed, and the RIM is functioning as the primary intelligence module.	Replace the intelligence module. Refer to module replacement procedure.
	IIC inter-module communications failed.	The communications between the MIM and at least one other module failed.	Call your contract service provider or APC Technical Support.



### Service

---

If the UPS requires service, do not return it to the dealer! Follow these steps:

1. Review the problems discussed in the *Messages* chapter to eliminate common problems.
2. Verify that no circuit breakers are tripped. A tripped circuit breaker is the most common UPS problem!
3. If the problem persists, call customer service or visit the APC Internet Website at <http://www.apc.com/support>.
  - Note the model number of the UPS, the serial number, and the date purchased. A technician will ask you to describe the problem and try to solve it over the phone, if possible. If this is not possible, the technician will issue a Returned Material Authorization Number (RMA#).
  - If the UPS is under warranty, repairs are free. If not, there is a repair charge.
4. Pack the UPS in its original packaging. If the original packing is not available, ask customer service about obtaining a new set. Visit the APC web site at <http://www.apc.com/support> for customer support telephone numbers.
5. Pack the UPS properly to avoid damage in transit. Never use polystyrene beads for packaging. Damage sustained in transit is not covered under warranty.
6. Mark the RMA# on the outside of the package.

**CHAPTER 5: MAINTENANCE**